



Integrated energy efficiency evaluation of a multi-source multi-load desalination micro-energy network

Dan Wang¹, Jiancheng Yu², Bo Liu¹, Chao Long³, Peiyu Chen⁴, Zhiqiang Chong⁴

1. Key Laboratory of Smart Grid of Ministry of Education, Tianjin University, Nankai District, Tianjin 300072, P.R. China

2. State Grid Tianjin Electric Power Company, Hebei District, Tianjin 300010, P.R. China

3. Centre for Energy Systems and Strategy in School of Water, Energy and Environment, Cranfield University, College Road Cranfield MK43 0AL, United Kingdom

4. Electric Power Research Institute of State Grid Tianjin Electric Power Company, Xiqing District, Tianjin 300384, P.R. China



Scan for more details

Abstract: With increasing global shortage of fresh water resources, many countries are prioritizing desalination as a means of utilizing abundantly available seawater resources. Integrated energy efficiency evaluation is a scientific method for the quantitative analysis of energy efficiency based on multiple indicators and is very useful for investment, construction, and scientific decision-making for desalination projects. In this paper, the energy efficiency evaluation of the micro energy network (MEN) of desalination for multi-source and multi-load is studied, and the basic idea of comprehensive energy efficiency evaluation is analyzed. The process includes the use of a MEN model to establish an integrated energy efficiency evaluation index system, taking into consideration energy, equipment, economic, environmental, and social factors. A combined evaluation method considering subjective and objective comprehensive weights for multi-source multi-load desalination MENs is proposed to evaluate the energy efficiency of desalination and from multiple perspectives.

Keywords: Seawater Desalination, Micro-energy Network, Integrated Energy Efficiency Evaluation, Index System, Evaluation Method.

1 Introduction

Water is essential for all forms of life on earth and is an irreplaceable natural and strategic resource for maintaining the functions of earth's ecosystem and the development of the socio-economic system [1]. Presently, more than half

of the countries and regions of the world lack effective access to clean drinking water. This is especially the case in developing countries, where more than one billion people are without a stable supply of clean fresh water [2]. China is one of the 13 most water-deficient countries identified by the United Nations, with a per capita share of fresh water of only one quarter of the world's average, and is in urgent need of new technologies for discovering stable sources of fresh water.

Seawater accounts for more than 97% of the earth's total water resource. Hence, desalination technology for exploiting this huge resource through the evolved use of simple principles has become the prime focus of some countries for solving the freshwater shortage problem [3],

Received: 30 November 2019/ Accepted: 15 February 2020/ Published: 25 April 2020

✉ Dan Wang
wangdantjuee@tju.edu.cn

Jiancheng Yu
yujiancheng@126.com

Bo Liu
boliustu@126.com

Chao Long
Chao.Long@cranfield.ac.uk

Peiyu Chen
chenpeiyu400@sina.com

Zhiqiang Chong
18622568323@163.com

[4]. Table 1 shows the development of desalination in the world

Table 1 The development of desalination in the world

Places	Characteristic
Chennai desalination plant, India	Largest desalination plant in South Asia at the time of its completion [5].
Hadera desalination plant, Israel	Largest in the world at the time of its construction [6].
Kuwait	First country to use desalination technology for the large-scale supply of household water [7].
Spain	A series of laws were passed to promote the development of desalination [8].
Sicily, Italy	Desalination plant built 20 years ago can provide 20% local freshwater supply [9].
Hamma Desalination Plant, Algeria	The largest in Africa [10-11].
Trekkoppje Plant, Namibia	Solar energy for the desalination process [12].
China	More than 150 desalination plants have been built and the technologies approaching advanced international level [13-14].

However, desalination is an “energy for water” technology, with the energy consumption accounting for more than a third part of the total cost [15]. Improvement of the energy utilization efficiency of the process has been approached through the combined use of renewable energy, energy storage, multi-energy conversion equipment, desalination units, and other components to form a multi-source multi-load micro-energy network (MEN). This enables maximum utilization of the renewable resources through simultaneous application to cooling, heating, and electricity generation [16].

The MEN of a multi-source multi-load desalination plant contains substantial energy sources, various internal energy conversion equipment, and multiple outputs. Scientific and reasonable measurements of the energy utilization and output efficiency are important to the development and application of the process. Integrated energy efficiency evaluation is a scientific method for quantitatively analyzing the energy utilization and output efficiencies of desalination through a series of scientific indicators. It is a powerful investment, construction, and operation decision-making tool for desalination projects, enabling scientific, reasonable, and objective evaluation and quantitative analysis of a multi-source multi-load MEN. Further, integrated energy efficiency evaluation enables

the determination of the key theories and technologies that afford significant energy efficiency improvement, thereby providing a basis and technical support for the construction of desalination plants and development of energy efficiency improvement strategies.

Regarding energy efficiency evaluation for desalination, there has been the proposal [17] of a new technological concept of ideal reverse osmosis that enables a more appropriate assessment of the energy efficiency of water desalination. In [18], the seawater desalination energy utilization efficiency was evaluated from the perspectives of the feed flow rate, pressure, and temperature, and a strategy for improving the energy efficiency was presented. In [19], the main energy efficiency indexes of desalination, such as the thermal efficiency, equivalent power consumption rate, and fuel consumption rate, were established and analyzed. In [20], aiming at a water desalination project with combined production of hydropower, the energy consumption indexes of power consumption, steam consumption and chemical consumption are established and the calculation method is given to analyze the impact on system operation.

The above-mentioned works provide a reference for energy efficiency analysis of desalination. However, there is presently no method with a broad model compatibility and complete index system that is globally applicable for an objective and comprehensive evaluation of the desalination process. An overall evaluation of the energy efficiency of a multi-source multi-load desalination MEN does not meet the current need for simultaneous transformation of the multi-source multi-load desalination process and improvement of its energy efficiency. Therefore, in the present study, beginning with the process of energy efficiency evaluation of a multi-source multi-load desalination MEN, a model for evaluation of the desalination process was established. The characteristics of the existing multi-source multi-load MEN were analyzed and an integrated energy efficiency evaluation index system that considers multiple factors was established. This paper also reviews existing integrated energy efficiency evaluation methods and identifies their inherent problems.

2 Model and integrated energy efficiency evaluation of multi-source multi-load desalination MEN

2.1 MEN model

A multi-source multi-load desalination MEN is a complex multi-input multi-output energy system. Ideal engineering models of the system are shown in Fig. 1 and 2. The multi-source characteristic of the system mainly relates

to the source side, which includes renewable resources and a grid access, as well as energy storage for when there is insufficient power. The first part of the system utilizes the thermal load method or membrane method.

Thermal desalination, which is also referred to as distillation desalination, involves the injection of the pre-treated seawater into the multi-stage evaporator, heating and vaporization of the seawater in the evaporator, and cooling to fresh water in the multi-stage condenser [21], [22]. The main energy-consuming equipment of the thermal desalination process is the evaporator, which is connected to the system as a part of the heat

load. Membrane seawater desalination is also referred to as osmotic seawater desalination. It is based on the application of a pressure greater than the osmotic pressure to the seawater side through the multi-stage pressure pump driven by electric power. The water molecules are separated from the impurities such as salt to obtain fresh water through the osmotic system composed of a multi-stage osmotic membrane [23], [24]. The main energy-consuming equipment of membrane desalination is the pressure pump used to transport the seawater. The pump can be regarded as part of the electrical load of the system.

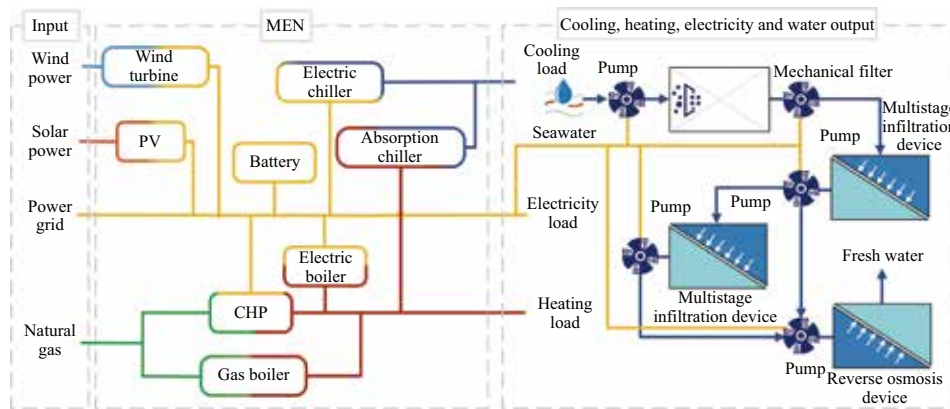

Fig. 1 Engineering model for membrane desalination

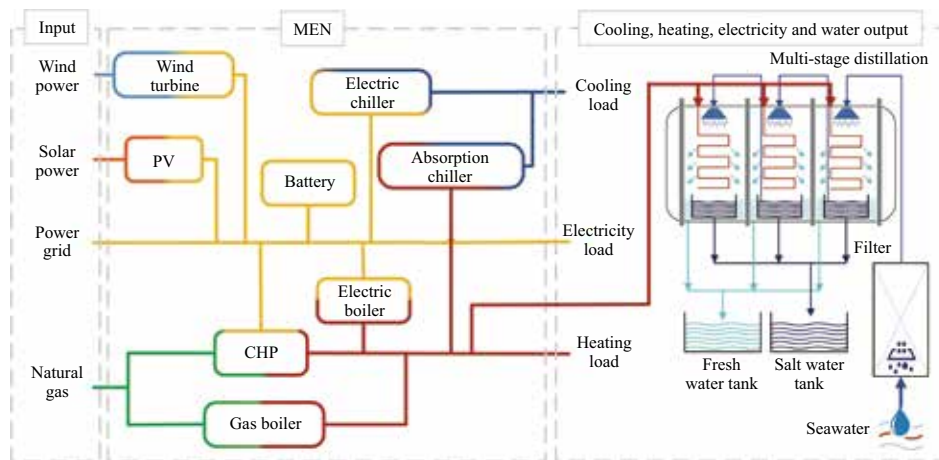

Fig. 2 Engineering model for thermal desalination

Table 2 Parts of the multi-source multi-load system

Part of system	Content	Part of system	Content
Multi-energy conversion equipment	Combined heat and power	Multi-source	Photovoltaics and wind turbines
	Gas boilers		Electric supply
	Electric boilers	Multi-load	Energy storage
	Electric chillers		Cooling, heating, and electricity loads
	Absorption chillers		Desalination load

The second part of the multi-load system includes the support cooling, heating, and electric loads of the desalination process. This is used to enhance the economy of the desalination system. The second part of the multi-load system also includes the chiller, boiler, cogeneration system, and other multi-energy conversion equipment. The various parts of the multi-source multi-load system are detailed in Table 2.

2.2 Basic process of integrated energy efficiency evaluation

On the multi-source side of the above system model, the output of the renewable resources is significantly seasonal, periodic, and regional. For example, the wind resources on the southeast coast and islands of China are stronger than those in the northern coastal areas. Additionally, the photovoltaic resources in the country are stronger in summer than in winter. On the multi-load side, the desalination load and the cooling, heating, and electricity loads are significantly affected by the climatic conditions and lifestyle of the users. Moreover, significant differences occur among the data used for planning, construction, operation, and implementation of a desalination plant. Therefore, it is of great significance to develop a unified, reasonable, and universal evaluation index system and evaluation scheme for a desalination plant, taking into consideration the various types of utilized equipment and the complex connections and energy transfer between them. An integrated energy efficiency evaluation process for the multi-source multi-load desalination MEN model described in this paper is illustrated in Fig. 3.

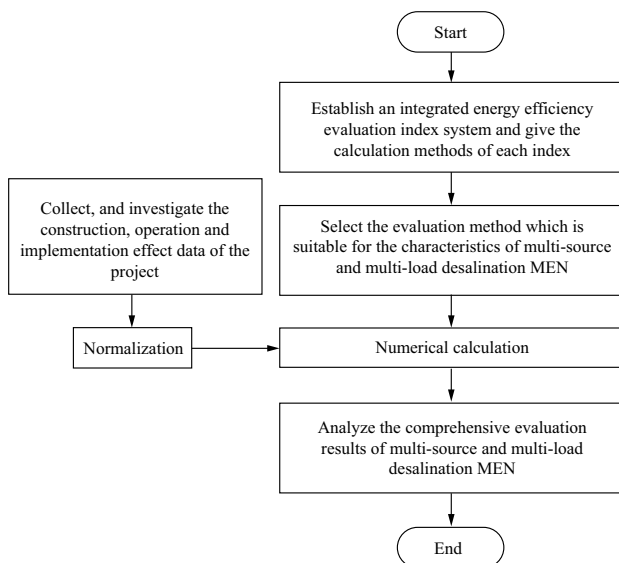

Fig. 3 Integrated energy efficiency evaluation of a multi-source multi-load desalination MEN

The evaluation involves the following steps:

1) Establishment of an integrated energy efficiency evaluation index system and the calculation method for each index. The selection of comprehensive evaluation indexes is in accordance with the principles of systematization, nature, and comparability. On the one hand, the indexes should correctly and comprehensively reflect the actual condition of the system. On the other hand, the ease of data collection and the computation load should be taken into consideration [25], [26]. In [27], the Delphi method is used to establish the customer evaluation index system for electricity sales through consultation with scholars and power marketing personnel. In [28], a performance function is used to preprocess the established qualitative and quantitative indexes to better reflect the actual situation. In [29], the index system is divided into two levels, namely the macro-demand index set and micro-evaluation index set. A comprehensive evaluation system is established by considering the interdependence and influence degrees of the indexes. In the present study, based on the above principles and methods, an evaluation index system that considers the energy consumption, equipment type, and economic, environmental, and social factors was established. The calculation methods were developed to achieve an integrated energy efficiency evaluation system for a multi-source multi-load desalination MEN.

2) Selection of an evaluation method that is suitable for the characteristics of a multi-source multi-load desalination MEN. A comprehensive evaluation method usually includes subjective and objective aspects. The subjective evaluation involves expert advice based on an analytic hierarchy process (AHP) [30], while the objective evaluation is based on the information collected from the objective evaluation and involves and is an entropy weight method [31]. The details will be discussed in Section 4.

3) Numerical calculation. The integrated energy efficiency evaluation data of a multi-source multi-load desalination MEN are collected during the construction and operation of the plant and through examination of their potential effect. Because of the differing scales and operation processes of different plants, the original data used for calculation are first normalized for unification and comparability [32].

4) Analysis of the comprehensive evaluation results. The calculation results are used for quantitative comparative analysis of the multi-source multi-load desalination MEN based on the multiple levels of the evaluation indexes to obtain the final evaluation results.

3 Integrated energy efficiency evaluation index system for multi-source multi-load desalination MEN

3.1 Energy efficiency indicators

Recent years have witnessed increasing research on the reduction of dependence on fossil fuel and the carbon footprint through the use of renewable energy and energy storage, such as on the source side of the energy structure of a desalination plant. This energy perspective has become the key to measuring the energy efficiency of a desalination MEN. In [33], to spread out the cost of the desalination process, light and heat are used as the energy source of the distillation system, and wind turbines as the energy source of the steam compressor. In [34], wind turbines and desalination are combined in a MEN to reduce the fossil energy consumption of desalination. In [35], the authors propose a high-efficiency desalination system that uses renewable energy and natural vacuum technology. In [36], wind and light hybrid renewable energy is used for energy-efficient multi-effect evaporation desalination.

In the present study, an energy efficiency indicator I_{ENE} was established to reflect the renewable energy efficiency level, energy storage efficiency level, electric energy efficiency level, heat energy efficiency level, and cooling energy efficiency level of a multi-source multi-load desalination MEN. The renewable energy efficiency η_{RE} was defined to evaluate the overall energy efficiency of the system, as follows:

$$\eta_{RE} = \frac{P_p + P_T}{P_A} \quad (1)$$

where P_p is the total annual photovoltaic power generated by the system; P_T is the total annual wind power generated; and P_A is the theoretical annual maximum renewable energy generated.

The energy storage system stores the surplus electric energy generated from the renewable energy and releases it when there is a shortfall in the energy generation to ensure normal operation of the system. The energy storage efficiency η_{ST} is given by

$$\eta_{ST} = \frac{P_{out}}{P_m} \quad (2)$$

where P_{out} is the discharge capacity of the energy storage system, and P_m is the charge capacity.

A seawater desalination MEN has three forms of energy output, namely cooling energy, heating energy, and electric energy. The output and utilization efficiencies for these three forms of energy are important indicators of the energy efficiency of a multi-source multi-load system. The electric energy efficiency η_E is given by

$$\eta_E = \frac{P_{EL} + P_{EI} + P_{EW}}{P_{RE} + P_S + P_G} \quad (3)$$

where P_{EL} is the electric energy generated by the multi-source multi-load system; P_{EI} is the electric energy consumed by the electric chillers, electric boilers and other equipment; P_{EW} is the electric energy consumed by the water desalination process; and P_{RE} , P_S , and P_G are respectively the renewable energy generated, the stored energy, and the grid power supplied by the multi-source multi-load system.

The heat energy efficiency η_H is given by

$$\eta_H = \frac{Q_{HL} + Q_{HI} + Q_{HW}}{Q_{CHP} + Q_{GB} + Q_{EB}} \quad (4)$$

where Q_{HL} is the thermal energy supplied by the micro-energy grid; Q_{HI} is the heat energy consumed by the absorption chiller and other equipment; Q_{HW} is the heat energy consumed by the water desalination process; and Q_{CHP} , Q_{GB} , Q_{EB} are respectively the heat energy produced by the CHP, gas boiler, and electric boiler of the multi-source multi-load system.

The cooling energy efficiency η_C is given by

$$\eta_C = \frac{Q_{CL} + Q_{CI}}{Q_{EC} + Q_{AC}} \quad (5)$$

where Q_{CL} is the cooling energy supplied by the multi-source multi-load system; Q_{CI} is the cooling energy consumed by the system; and Q_{EC} and Q_{AC} are respectively the cooling energy consumed by the electric chillers and absorption chillers.

3.2 Energy efficiency index

The multi-source multi-load desalination MEN includes energy generation equipment, energy conversion equipment, desalination equipment, and other equipment. Diverse studies have been conducted on these equipment. In [37], a desalination system with renewable energy is optimized using gas turbine and multi-stage flash cycle equipment for more efficient energy utilization. In [38], the authors improve the traditional energy recovery equipment through significant enhancement of the energy utilization efficiency of the reverse osmosis desalination system. In [39], a solar dish concentrator is used to improve the renewable energy generation of a desalination system and the distillation efficiency. This previous works reveal that the utilized equipment and their operation state significantly impact the energy efficiency of the MEN. The energy efficiency index of each equipment is key to measuring the integrated energy efficiency of the MEN.

The energy efficiency index of an equipment, I_{DEV} , is determined by the energy conversion efficiency, energy utilization rate, failure rate, service life, operation pattern,

and maintenance coefficient of the equipment. The average energy conversion efficiency η_{EC} of the equipment is given by

$$\eta_{EC} = \frac{1}{n+1} \left(\sum_{i=1}^n \frac{E_{out}}{E_{in}} + \frac{M_{FW}}{M_{SW}} \right) \quad (6)$$

where E_{out} is the energy output of the equipment; E_{in} is the energy input; n is the number of energy conversion equipment in the MEN; M_{FW} is the fresh water output of the desalination system; and M_{SW} is the amount of utilized desalinated seawater.

The energy utilization rate η_{EU} of the equipment is given by

$$\eta_{EU} = \frac{1}{n+1} \left(\sum_{i=1}^n \frac{T_{AU}}{T_{PU}} + \frac{T_{WAU}}{T_{WPU}} \right) \quad (7)$$

where T_{AU} is the number of actual operation hours of the equipment per day; T_{PU} is the maximum number of operation hours per day; n is the number of equipment in the MEN; T_{WAU} is the actual number of operation hours of the desalination unit per day; and T_{WPU} is the maximum number of operation hours of the unit per day.

The equipment failure rate η_{EF} is given by

$$\eta_{EF} = \frac{1}{n+1} \left(\sum_{i=1}^n \frac{T_{FT}}{T_{NT}} + \frac{T_{WFT}}{T_{WNT}} \right) \quad (8)$$

where T_{FT} is the downtime of the equipment due to failure; T_{NT} is the normal operation time of the equipment; n is the number of equipment in the MEN; T_{WFT} is the failure shutdown time of the desalination unit; and T_{WNT} is the normal operation time of the desalination unit.

The service life of the device T_{EU} is given by

$$T_{EU} = \frac{1}{n+1} \left(\sum_{i=1}^n t_{EU} + t_{WU} \right) \quad (9)$$

where t_{EU} is the expected service life of the equipment under normal use; n is the number of equipment in the MEN; and t_{WU} is the expected service life of the MEN under normal use.

The maintenance coefficient R_{OM} of the equipment is given by

$$R_{OM} = \frac{1}{n+1} \left(\sum_{i=1}^n \frac{t_{MA}}{t_{OP}} + \frac{t_{WMA}}{t_{WOP}} \right) \quad (10)$$

where t_{MA} is the time spent on maintenance of the equipment during an operation cycle; t_{OP} is the normal operation time of the equipment during an operation cycle; n is the number of equipment in the multi-source multi-load seawater desalination system; t_{WMA} is the time spent on maintenance of the desalination unit during an operation cycle; and t_{WOP} is the duration of a normal operation cycle.

3.3 Economic energy efficiency index

The economic benefit of a multi-source multi-load

desalination MEN is important to its promotion and development. In [40], the authors present an economic feasibility model for evaluating the technical economy of the Karachi Nuclear Power Plant. In [41], the authors conduct an economic analysis of a distillation system in Jordan composed of flat plate collectors, photovoltaic panels, spiral air gap membrane distribution modules, and a data acquisition system. The authors of [42] conducted a study on the economics of forward and reverse osmosis hybrid desalination systems and propose some guidelines for improving the economic competitiveness of the hybrid process.

The economic energy efficiency index I_{ECO} proposed in this paper considers the system integrated energy cost, investment cost, operation and maintenance costs, output benefit, and comprehensive rate of return. It promises to be useful for analysis of the system energy input and output. The integrated energy cost W_{EC} is given by

$$W_{EC} = W_{ELE} + W_{GAS} + W_{WAT} \quad (11)$$

where W_{ELE} is the power purchase cost for the operation of the system on a typical operation day; W_{GAS} is the gas purchase cost; and W_{WAT} is the acquisition cost of seawater for the desalination process.

The system investment cost W_{SI} is given by

$$W_{SI} = W_{DI} + W_{WI} + W_{OI} \quad (12)$$

where W_{DI} is the fixed investment cost of the system equipment; W_{WI} is the investment cost of the desalination unit; and W_{OI} is the investment cost of the other components of the system, such as pipeline construction, land use and the medicine cost for pretreatment of raw seawater.

The system operation and maintenance cost W_{OM} is the cost of the operation and maintenance of the system during an operation cycle. The system output benefit W_{OB} is given by

$$W_{OB} = W_{Eload} + W_{Hload} + W_{Cload} + W_{Wload} \quad (13)$$

where W_{Eload} , W_{Hload} , W_{Cload} , and W_{Wload} are respectively the revenues generated from the supply of electricity, heating, cooling, and fresh water.

The return on investment W_{AB} is the ratio of annual average profit W_{PR} and total investment W_{TI} of the system after deducting inflation factors. It is given by

$$W_{AB} = \frac{W_{PR}}{W_{TI}} \quad (14)$$

3.4 Environmental and social energy efficiency indicators

A multi-source multi-load desalination MEN uses and converts local renewable and non-renewable energy resources. Through micro-energy integration, it provides local cooling, heating, and electricity and water supply.

Environmental and social energy efficiency indicators can be used to determine the relationship between the energy consumption of the system and its environmental impact and social contribution. To assess the environmental and social impacts of the system, the authors of [43] used the life cycle assessment method. Reference [44] presents a detailed examination of a desalination plant in Israel from the perspectives of energy demand, environmental policy, and decision-making. The authors of [45] investigated the potential impacts of desalination plants and the public perception of such facilities.

The environmental and social energy efficiency index I_{SOC} developed in the present study includes five sub-indicators, namely the pollutant emission energy efficiency, waste energy efficiency, environmental contribution energy efficiency, user energy efficiency identification, and social energy efficiency identification. The pollutant emission energy efficiency η_{CE} is given by

$$\eta_{CE} = \frac{\sum_{i=1}^m G_m}{W_{EIN}} \quad (15)$$

where W_{EIN} is the total energy input, including renewable energy, electric energy, and chemical (gas) energy; G_m is the emitted amount of a particular pollutant; and m is the number of pollutants.

The waste energy efficiency η_{WE} is given by

$$\eta_{WE} = \frac{\sum_{i=1}^m H_m}{W_{EIN}} \quad (16)$$

where H_m is the generated amount of a particular waste, and m is the number of wastes.

The environmental contribution energy efficiency η_{ED} is given by

$$\eta_{ED} = \frac{M_p + M_T}{M_C + M_p + M_T} \quad (17)$$

where M_p and M_T are respectively the reductions in the amount of carbon dioxide emission afforded by photovoltaic and wind power generation; and M_C is the total amount of nonrenewable energy resources consumed by the operation of the system.

The user energy efficiency identification I_U is given by

$$I_U = \frac{1}{4}(I_{UC} + I_{UH} + I_{UE} + I_{UW}) \quad (18)$$

where I_{UC} , I_{UH} , I_{UE} , and I_{UW} are the average scores of local users' satisfaction of cooling, heating, electric, and water services through questionnaire survey.

The social energy efficiency identification I_S is given by

$$I_S = \frac{1}{3}(I_{SU} + I_{SE} + I_{SS}) \quad (19)$$

where I_{SU} , I_{SE} , I_{SS} are the average scores of public service experts on user service, environmental contribution and social satisfaction identification through questionnaire survey.

The degree of identification is a subjective measure that can be determined by a questionnaire survey of users or other similar methods. The measure ranges between 1 and 9, where 1 indicates "very dissatisfied," and 9 "very satisfied" (see Table 3 for further details).

Table 3 Identification degree rules

Degree of satisfaction I	Score
Very dissatisfied	1
Dissatisfied	3
Generally satisfied	5
Satisfied	7
Very satisfied	9
Intermediate scores	2, 4, 6, 8

3.5 Integrated energy efficiency evaluation index system

Based on the established energy, equipment, economic, environmental, and social energy efficiency indexes, an integrated energy efficiency index system for a multi-source multi-load desalination MEN was developed. The hierarchy of the index system is shown in Fig. 4. This evaluation system is divided into three layers. The first layer is the evaluation target layer, which enables quantitative evaluation of the construction and transformative effect of the system. The second layer is the evaluation criteria layer, which enables specific criteria-based evaluation of the energy, equipment, economic, environmental, and societal effects of the system. It can be used to screen and evaluate the system in a specific field. The third layer is the evaluation index layer, which includes specific sub-indicators of each evaluation criterion.

4 Integrated energy efficiency evaluation method for multi-source multi-load desalination MEN

The proposed comprehensive evaluation method is based on multiple evaluation indexes and levels. It can be used for quantitative analysis and assessment of the evaluation objectives based on certain procedures or models. The method utilizes an analytic hierarchy process (AHP), the entropy weight method (EWM), the grey correlation degree

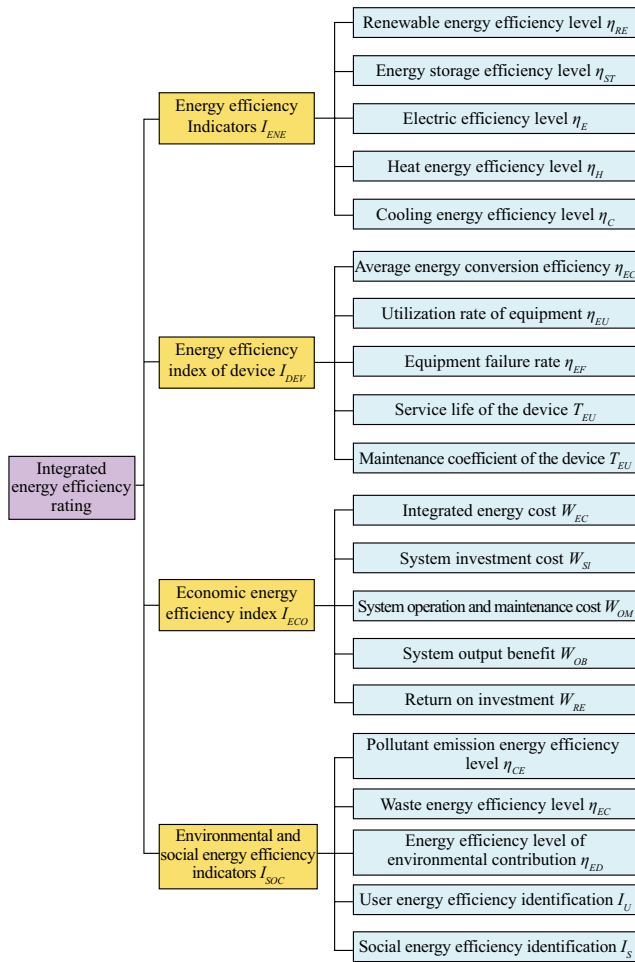

Fig. 4 Integrated energy efficiency index system

method, and the combination analysis method. In its actual application, the third level indicators can be calculated using the project plan, construction and operation data, and the equations presented in sections 3.1–3.4 above.

4.1 Subjective evaluation method

AHP is a comprehensive evaluation method commonly used in various fields. In [46], a method for combining fuzzy comprehensive evaluation and AHP based on the determined risk index is introduced. The weight vector for the fuzzy comprehensive evaluation is determined by AHP. The proposed method was applied to a large-scale desalination project. In [47], indexes such as the geothermal energy development and utilization, thermal breakthrough time, average heat production rate, total heat recovery rate, and reinjection utilization rate are established for evaluation of a geothermal exploitation process based on AHP and fuzzy comprehensive evaluation. In [48], the authors identify some risk factors through a questionnaire survey and literature review and use fuzzy AHP to comprehensively calculate the overall risk of a clean power generation plant

with energy storage at its core. In [49], AHP method is used to determine the weights of the evaluation indexes of the energy efficiency of an energy distribution network. The integrated energy efficiency is subsequently determined and the weak link in the energy distribution network is identified. Based on AHP, the authors of [50] established a layer-by-layer judgment matrix for the comprehensive evaluation of the development level of the power market, taking into consideration the subjectivity of expert qualitative analysis. The integrated energy efficiency evaluation index system established in the present work is a multi-level system. It is thus suitable for application to the AHP method. For this purpose, the judgment matrixes of the relative importance of the indexes for the target layer, criterion layer, and index layer should first be constructed in the criterion layer through expert consultation and other methods. Secondly, the judgment matrix of the criterion layer is tested for consistency, and the corresponding weight vector is then calculated. Subsequently, the weight vector of the criterion layer to the target layer is determined by expert consultation and other methods to calculate the comprehensive weight of each evaluation index of the desalination MEN. Finally, together with the use of basic investment, construction, and operation data, the integrated energy efficiency of the system can be analyzed.

4.2 Objective evaluation method

However, as a kind of subjective weighting method, the results of the practical application of the AHP method is affected by subjective factors such as user engineering experience and professional level. Hence, a more objective evaluation method was developed for comprehensive evaluation in the present study. Based on the original data, objective weighting was applied to each evaluation index to avoid dependence of the evaluation results on human subjective perception. This affords a strong mathematical assessment. Commonly used objective weighting methods include the EWM and the technique for order preference by similarity to an ideal solution (TOPSIS).

In [51], a multi-attribute decision-making method based on the EWM is used to analyze and evaluate some reactive power optimization alternatives, determine the objective weight of each of the evaluation indexes, and rank the alternatives. In [52], the authors propose an EWM-based microgrid vulnerability assessment method that considers the randomness of the distributed power generation and load. The method enables an objective determination of the effects of the inherent structural characteristics and internal energy distribution of the microgrid. In [53], a comprehensive system for evaluating the state characteristics

of a low-voltage distribution network is presented. The objective weights of the different evaluation indexes are determined by the EWM based on the characteristics of the evaluation data.

The presently proposed integrated energy efficiency evaluation method for a desalination MEN considers the energy efficiency indicators, equipment energy efficiency index, economic energy efficiency index, and environmental and social energy efficiency index. This represents a multi-attribute decision-making problem. The objective weight of each attribute index can be determined based on information entropy. Firstly, the input data are initialized to obtain several alternative schemes of the desalination MEN. We considered a multi-attribute decision-making problem with four evaluation indexes and N alternative schemes and constructed the evaluation index matrix. The matrix was standardized using the rule of the larger the index, the better or worse the result. The entropy and entropy weight of each evaluation index was then determined. The smaller the information entropy, the greater the information that was obtained and the larger was the objective weight. Conversely, the larger the information entropy, the smaller was the objective weight. Finally, the comprehensive weight was determined.

However, when the information entropy of the EWM approaches 1, the weight will become unreasonable. In this case, the EWM can be improved by adjusting the weight, or TOPSIS can be used for a comprehensive evaluation. TOPSIS fully utilizes the available data and eliminates the influence of dimension. It is easy to use in combination with other methods. In [54], the authors propose a method for evaluating the influence of the air supply blade angle on the energy utilization and thermal comfort afforded by an air conditioning system. TOPSIS was used to evaluate the influence of various parameters. However, in view of the problem that TOPSIS has a reverse order, which causes multi-dimensional problems, a scheme with a closer positive order ideal solution may be used to obtain a closer negative ideal solution. The authors of [55] used the absolute positive and negative ideal point theory and the projection approach method to improve TOPSIS and evaluate the planning scheme. The reverse order of TOPSIS produced a scheme that was closer to the positive order ideal solution for multidimensional problems, rather than closer to the negative ideal solution. In [55], TOPSIS is improved by the absolute positive and negative ideal point theory and a projection-type approach degree method for the evaluation of planning schemes.

Therefore, in the evaluation of the integrated energy efficiency of a desalination MEN, the EWM can be used

to determine the objective weight of each index. After normalization and weighting of the index matrix, the standardized weighted decision matrix can be obtained. The optimal energy efficiency value corresponding to each of the four indexes is obtained as a positive ideal solution, and the worst energy efficiency value as a negative ideal solution. The “vertical” distance between the index value corresponding to each decision and the positive and negative ideal solution is then calculated. The comprehensive evaluation can then be completed using the ratio between the approaching degree of each decision index to its positive ideal solution and its alienating degree to its negative ideal solution. The greater the ratio, the better the evaluation, and vice versa.

4.3 Combinational evaluation method

Objective weighting can be used to eliminate the impact of subjective factors. However, it does not reflect the degrees of subjective preference of the evaluation attributes. It also requires a large amount of data input and has a low applicability. The weights obtained by this method may be significantly unrepresentative of the actual relative importance of the attributes. Considering the characteristics of subjective and objective evaluation, a combination of the two is reasonable, enabling exploitation of their respective advantages to achieve a better comprehensive evaluation.

In [56], a comprehensive evaluation index system is established for an electric vehicle based on the multiple attributes of the battering fast charging network and the coupling relationships within the network. The AHP method is used to determine the criterion layer while the EWM is used to determine the weight of the index layer. A fuzzy comprehensive evaluation algorithm with hierarchical recursive characteristics is used to quantify the impact of the fast charging network. Further, aiming at a four-tier evaluation index system, the authors of [57] propose a hierarchical evaluation method for an intelligent distribution network. The method combines the improved order analysis method (G1) with TOPSIS. The weights are first determined by the G1 method and then improved by TOPSIS to achieve a more accurate evaluation. In [58], based on the fuzzy analytic hierarchy process (FAHP), similarity clustering analysis is used to determine the static subjective weights of the indexes, while an index weight determination method based on index correlation (CRITIC) is used to determine the dynamic objective weight. A new risk assessment model of an intelligent distribution network is developed by combining the two sets of weights into optimal variable weights. In [59], an analytic network process and anti-entropy weight method are used to determine the weights

and scoring functions of the indicators. This procedure solves the weighting inaccuracy problem caused by the cross meaning and mutual influence of the indicators in the evaluation of a regional integrated energy system. In [60], AHP, CRITIC, and TOPSIS are combined to develop an evaluation method for a transmission network planning scheme. AHP and CRITIC are used to obtain the subjective and objective weights of the indexes, which are combined to obtain the comprehensive weights. TOPSIS is then used to sort the schemes.

In the foregoing previous works, a subjective evaluation method was used to consider the degrees of the individual subjective preferences. This approach has the advantage of calculation convenience, but it is too subjective. While objective evaluation can be used to address this subjectivity, it involves complex calculation and the applicability is low. In the integrated energy efficiency evaluation method for a desalination MEN proposed in this paper, subjective weighting is first applied to the evaluation indexes, and objective weighting is then used to consider the large amount of information contained in the indexes. The principle of minimum discrimination information is subsequently used to determine the comprehensive weights of the indexes. This evaluation method effectively combines the advantages of subjective and objective weighing, weakening the subjectivity of the former without entirely losing it. It affords a more reasonable, comprehensive, and multi-perspectival evaluation of a desalination plan.

5 Conclusion

Integrated energy efficiency evaluation is the primary means of enhancing advanced energy systems. It is the basis for large-scale expansion of a multi-source multi-load seawater desalination MEN. However, there is presently no broadly applicable evaluation model and index system for the objective and comprehensive evaluation of the overall energy efficiency of a multi-source multi-load desalination MEN. With the aim of addressing this key problem of integrated energy efficiency evaluation, an ideal multi-source multi-load desalination MEN model applicable to both thermal and membrane desalination was established in the present study. The evaluation process involves establishment of the integrated energy efficiency index system, selection of an evaluation method, numerical calculation, and result analysis. Determination of the energy, equipment, economic, and environmental and social energy efficiencies are all included in the process. Existing evaluation methods were also analyzed and summarized.

The evaluation in this paper is mainly for the traditional

distillation and osmosis seawater desalination projects. There are still some imperfections in combination with the actual project. In the follow-up research, more detailed research will be conducted on the actual project, and more seawater desalination methods will be considered.

Acknowledgements

This work was supported by the State Grid Corporation of China project titled “Study on Multi-source and Multi-load Coordination and Optimization Technology Considering Desalination of Sea Water” (SGTJDK00DWJS1800011).

References

- [1] Yang YZ, Feng ZM, Sun T, Tang F (2019) Water resources endowment and exploitation and utilization of countries along the Belt and Road. *Journal of Natural Resources*, 34(6): 1146-1156
- [2] Verma R, Singh A, Khurana A (2017) Practices and attitudinal behavior about drinking water in an urban slum of district Rohtak, Haryana: a community-based study. *Journal of Family Medicine & Primary Care*, 6(3): 554
- [3] Duan SK, Shen GS, Shan ZD (2013) Measures to relieve the stress of water. *Applied Mechanics & Materials*, 361-363: 636-639
- [4] Jing W, Jing LS, Yang HC (2017) Research on development pattern of seawater desalination in China. *China Soft Science*, 12: 29-36
- [5] Arabindoo P (2011) Mobilizing for water: hydro-politics of rainwater harvesting in Chennai. *International Journal of Urban Sustainable Development*, 3(1): 106-126
- [6] Ganot Y, Holtzman R, Weisbrod N (2017) Monitoring and modeling infiltration recharge dynamics of managed aquifer recharge with desalinated seawater. *Hydrology & Earth System Sciences*, 21(9): 4479-4493
- [7] Darwish MA, Darwish A, Darwish A (2011) Fifty years of MSF desalination in Kuwait and sustainability issues. *Desalination and Water Treatment*, 29(1-3): 343-354
- [8] Molina VG, Casas A (2010) Reverse osmosis, a key technology in combating water scarcity in Spain. *Desalination*, 250(3): 950-955
- [9] Temstet C, et al (1996) A large high-performance MED plant in Sicily. *Desalination*, 105(1-2): 109-114
- [10] Abufayed A A (2001) Desalination: a viable supplemental source of water for the arid states of North Africa. *Desalination*. 139: 297-300
- [11] Mooij C (2007) Hamma Water Desalination Plant: planning and funding. *Desalination*, 203(1-3): 107-118
- [12] Dall EP, et al. (2017) The techno-economic optimization of a 100 MWe CSP-desalination plant in Arandis, Namibia. *AIP Conference Proceedings*, 2017
- [13] Tan YW, Tan B, Wang Q (2007) Progress in seawater desalination projects in China. *Technology of Water Treatment*, 33(1): 1-3

- [14] Hou-Jun F, Chun-Gang X (2010) Status and prospect of Chinese seawater desalination technology. *Chemical Industry and Engineering*, 27(2): 103-109
- [15] Zheng JB (2017) Study on operating optimization of high pressure seawater supply system for seawater reverse osmosis. Dissertation, Jiangsu University
- [16] Yu JC, Wang D, Yao C, Chen PY, Liu B (2019) Planning and design of a micro energy network for seawater desalination and regional energy interconnection. *Global Energy Interconnection*, 2(03): 224-234
- [17] Liu C, Rainwater K, Song L (2011) Energy analysis and efficiency assessment of reverse osmosis desalination process. *Desalination*, 276(1-3): 352-358
- [18] Alsarayreh AA et al. (2020) Evaluation and minimization of energy consumption in a medium-scale reverse osmosis brackish water desalination plant. *Journal of Cleaner Production*, 248: 119220
- [19] Zhang JH et al. (2009) Selection and application of key indicators of low-temperature multi-effect seawater desalination. *Energy Conservation & Environmental Protection*, 06: 25-28
- [20] Yi QW (2019) Discussion on energy consumption index of desalination system with combined hydropower generation. *Tianjin Chemical Industry*, 33(1): 32-33
- [21] Druetta P, Aguirre P, Mussati S (2013) Optimization of multi-effect evaporation desalination plants. *Desalination*, 311(Complete): 1-15
- [22] Al-Mutaz IS, Wazeer I (2014) Comparative performance evaluation of conventional multi-effect evaporation desalination processes. *Applied Thermal Engineering*, 73(1): 1194-1203
- [23] Fraidenraich N, et al. (2009) Reverse osmosis desalination: modeling and experiment. *Applied Physics Letters*, 94(12): 4975
- [24] Greenlee LF, Lawler DF, Freeman BD, et al (2009) Reverse osmosis desalination: Water sources, technology, and today's challenges. *Water Research*, 43(9): 2340-2348
- [25] Xiao J, et al. (2008) A hierarchical performance assessment method on the distribution network planning. *Automation of Electric Power Systems*, 32(15): 36-40
- [26] Wang ZD, et al. (2009) Assessment index system for smart grids. *Power System Technology*, (17): 20-24
- [27] Qingshan C, et al. (2018) Multi-attribute decision making model for customer evaluation and selection in electricity market. *Power System Technology*, 42(01): 128-138
- [28] Zhai B, Li CB, Tian HY (2007) Construction and methodology of comprehensive evaluation system for credit of industrial electricity customers. *Power System Technology*, 31(1): 87-90
- [29] Zhang XJ, et al. (2014) Comprehensive assessment system and method of smart distribution grid. *Power System Technology*, 38(1): 40-46
- [30] Zhao YF, Chen JF (2004) Analytic hierarchy process and its application in power system. *Electric Power Automation Equipment*, (9): 20-23
- [31] Luo Y, Li YL (2013) Comprehensive decision-making of transmission network planning based on entropy weight and grey relation analysis. *Power System Technology*, 37(1): 77-81
- [32] Yu L, Pan Y, Wu Y (2009) Research on data normalization methods in multi-attribute evaluation, *International Conference on Computational Intelligence and Software Engineering*, IEEE, 2009, 1-5
- [33] Fernández-López C, Viedma A, Herrero R (2009) Seawater integrated desalination plant without brine discharge and powered by renewable energy systems. *Desalination*, 235(1-3): 179-198
- [34] Zhang X, Huang K, Wang Y (2015) Operation and control of isolated microgrid with wind turbines and seawater desalination equipment. *International Conference on Electrical Machines & Systems*, Pattaya City, Thailand, 2015, 427-431
- [35] Ayhan T, Madani HA (2010) Feasibility study of renewable energy powered seawater desalination technology using natural vacuum technique. *Renewable Energy*, 35(2): 506-514
- [36] Yılmaz İH, Söylemez MS (2012) Design and computer simulation on multi-effect evaporation seawater desalination system using hybrid renewable energy sources in Turkey. *Desalination*, 291: 23-40
- [37] Hosseini SR, et al. (2012) Cost optimization of a combined power and water desalination plant with exergetic, environment and reliability consideration. *Desalination*, 285: 123-130
- [38] Wang Y, et al. (2016) Functionality test of an innovative single-cylinder energy recovery device for SWRO desalination system. *Desalination*, 388: 22-28
- [39] Omara ZM, Eltawil MA (2013) Hybrid of solar dish concentrator, new boiler and simple solar collector for brackish water desalination. *Desalination*, 326: 62-68
- [40] Khan SU, and Khan SU (2017) Karachi Nuclear Power Plant (KANUPP): as case study for techno-economic assessment of nuclear power coupled with water desalination. *Energy*, 127: 372-380
- [41] Banat F, Jwaied N (2008) Economic evaluation of desalination by small-scale autonomous solar-powered membrane distillation units. *Desalination*, 220(1-3): 566-573
- [42] Choi Y, et al. (2016) Economic evaluation of a hybrid desalination system combining forward and reverse osmosis. *Membranes*, 6(1): 3
- [43] Alhaj M, Al-Ghamdi SG (2019) Integrating concentrated solar power with seawater desalination technologies: a multi-regional environmental assessment. *Environmental Research Letters*, 14(7): 074014
- [44] Tal A (2018) Addressing desalination's carbon footprint: the Israeli experience. *Water*, 10(2): 197
- [45] Haddad B, Heck N, Paytan A (2018) Social Issues and Public Acceptance of Seawater Desalination Plants, *Sustainable Desalination Handbook*. Butterworth-Heinemann, 505-525
- [46] Zhang Y, et al. (2020) Risk evaluation of large-scale seawater desalination projects based on an integrated fuzzy comprehensive evaluation and analytic hierarchy process method, *Desalination*, 478: 114286
- [47] Guo T, et al. (2020) A coupled thermal-hydraulic-mechanical modeling and evaluation of geothermal extraction in the enhanced geothermal system based on analytic hierarchy process and fuzzy comprehensive evaluation. *Applied Energy*, 258: 113981

- [48] Liu J, Yin Y, Yan S (2019) Research on clean energy power generation-energy storage-energy using virtual enterprise risk assessment based on fuzzy analytic hierarchy process. *China Journal of Cleaner Production*, 236: 117471
- [49] Yang X, et al. (2013) Energy efficiency index system for distribution network based on analytic hierarchy process. *Automation of Electric Power Systems*, 37(21): 146-150+195
- [50] Wang Q, et al. (2009) Combined use of fuzzy set theory and analytic hierarchy process for comprehensive assessment of electricity markets. *Automation of Electric Power Systems*, 33(7): 32-37
- [51] Liu K, et al. (2017) Reactive Power Optimization in Distribution Network Based on Load Distribution Matching and Entropy Weight Method. *Power System Technology*, 41(12):3980-3988
- [52] Zhan X, Xiang T, Chen H (2014) The application of weighted entropy theory in vulnerability assessment and on-line reconfiguration implementation of microgrids. *Entropy*, 16(2): 1070-1088
- [53] Ji M, Xizhe L (2017) Conditional characteristic evaluation based on G2-entropy weight method for low-voltage distribution network. *Electric Power Automation Equipment*, 37(1): 41-46
- [54] NingSong M, Mengjie S, Shiming D (2016) Application of TOPSIS method in evaluating the effects of supply vane angle of a task/ambient air conditioning system on energy utilization and thermal comfort. *Applied Energy*, 180: 536-545
- [55] Zheshen W, et al. (2013) Optimal selection of planning schemes for power grid with high penetration of intermittent generation. *Power System Technology*, 37(08): 2129-2135
- [56] Qiqi N, et al. (2020) Comprehensive evaluation index system and method for fast charging network of electric vehicles. *Automation of Electric Power Systems*, 44(1): 83-91
- [57] Fengzhan Z, et al. (2016) Hierarchical Evaluation of Smart Distribution Grid Based on Improved G1-TOPSIS Method. *Power System Technology*, 40(10): 3169-3175
- [58] He G, et al. (2016) Risk assessment model of smart distribution grid. *Electric Power Automation Equipment*, (36): 147
- [59] Baisen C, et al. (2019) Comprehensive evaluation indices and methods for regional integrated energy system. *Automation of Electric Power Systems*, 39(3): 143-148,162
- [60] Shuqiang Z, Shanfa T (2019) Comprehensive evaluation of transmission network planning scheme based on improved analytic hierarchy process, CRITIC method and TOPSIS. *Electric Power Automation Equipment*, 39(3): 143-148

Biographies



Dan Wang received a Ph.D. degree from Tianjin University, Tianjin, China, in 2009 and became an Associate Professor at Tianjin University in 2015. His research interests include integrated energy systems, distributed generation systems, microgrid modeling and simulation, demand-side management, and power system stability analysis.



Jiancheng Yu received a Ph.D. degree from Tianjin University, Tianjin, China, in 2006 and he is currently working for the State Grid Tianjin Electric Power Company. His research interests include the energy internet, intelligent power generation technology, and demonstration project construction.



Bo Liu received a B.S. degree from the School of Mechano-Electronic Engineering at Xidian University, Shaanxi, China, in 2018 and he is now a graduate student at Tianjin University. His research interests include P2P energy transactions in microgrids,



Chao Long received a PhD degree from Glasgow Caledonian University, United Kingdom, in 2014. He is a Lecturer in Digital Energy Systems at Cranfield University, United Kingdom. He is with Centre for Energy Systems and Strategy in School of Water, Energy and Environment (SWEE). His research focuses on P2P energy trading, EVs and Blockchain technology.



Peiyu Chen received a M.S. degree from North China Electric Power University, Beijing, in 2007 and he is currently working for the Electric Power Research Institute of the State Grid Tianjin Electric Power Company. His research interests include power system analysis and renewable energy.



Zhiqiang Chong received a M.S. degree from North China Electric Power University, Beijing, in 2015 and he is currently working for the Electric Power Research Institute of the State Grid Tianjin Electric Power Company. His research interests include analysis of power system security and stability.

(Editor Dawei Wang)